

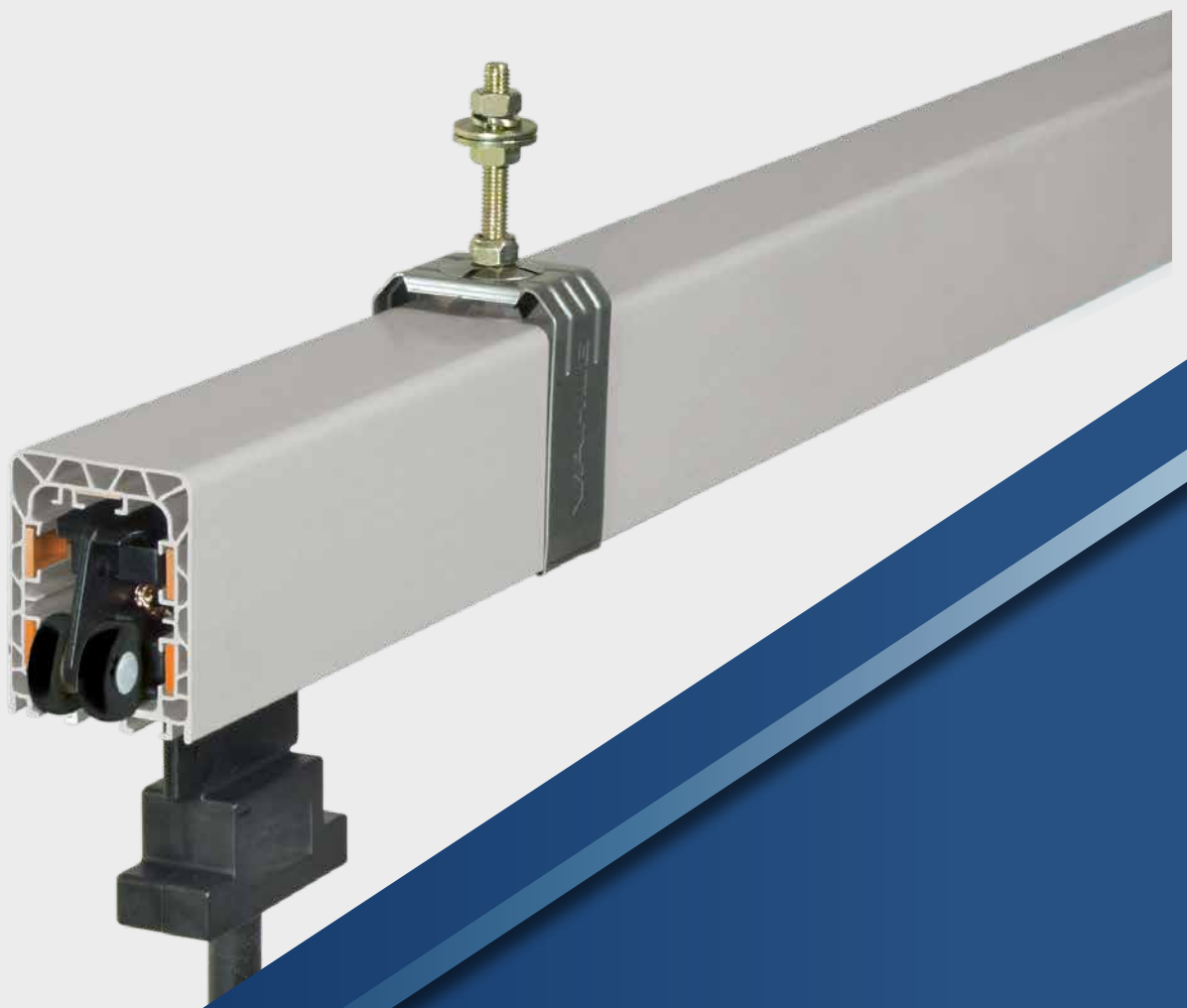

**ENCLOSED CONDUCTOR SYSTEM  
KBH**





# ENCLOSED CONDUCTOR SYSTEM KBH

## CONTENT

Enclosed conductor system KBH.....	3	Maintenance sections .....	21
Technical data .....	4	Anti-condensation section .....	22
Jointing material, hangers & end caps .....	8	Expansion section .....	23
Brackets.....	9	Single current collector .....	24
End feeds, line feeds .....	10	Double collector & tow arms .....	25
Line feeds .....	11	Flexible tow arm .....	26
Terminal box .....	12	Examples for ordering .....	27
Heating.....	14	Spare part list.....	29
Contact sections, turntables & switches .....	16	APOS Positioning system .....	30
Transfer funnels .....	17	VAHLE Powercom®.....	31
Transfer guides.....	18	Questionnaire .....	32
Transfer guides & conductor dead section.....	19	Pictures of plants .....	33
Removing section.....	20		

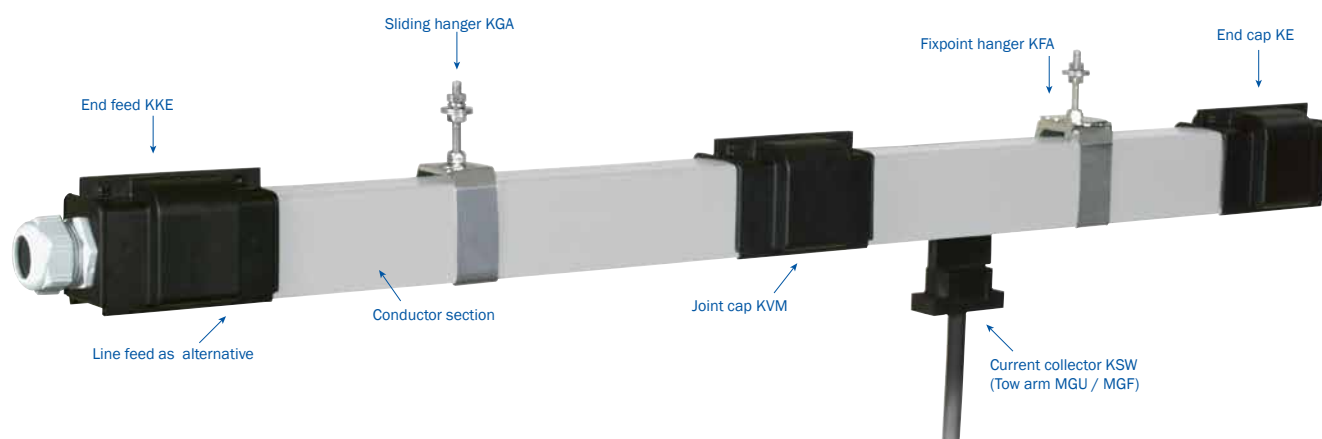

## DESCRIPTION OF THE CONDUCTOR SYSTEM

The VAHLE Powerail KBH is a shock hazard protected conductor system for indoor and outdoor installations. The plastic housing can accommodate different copper profiles.

Type KBHF: in 4- and 5-conductor version, with preassembled copper conductors and spring loaded connectors from 63 to 100 A.

Type KBHS: in 4- and 5-conductor version, with preassembled copper conductors and bolted joints from 63 to 200 A.

A compact design, corrosion resistance and an easy installation are the main characteristics. The KBH complies with VDE, european and international standards as well as accident prevention regulations. It is protected to IP 23 standards. The KBH can be supplied with sealing strip and heating system. The conductor system with sealing strip is protected to IP 24 standards and EN 60529 (0470, part 1) regulation.

Collectors are touch proof only when fully entered into the conductor system. If there is the possibility to touch live parts by hand, ie. collectors

that might leave the conductor system during operation, provide safety barrier or disconnect mains. This is valid only for a supply voltage exceeding 24 V AC or 60 VDC.

Other cross sections, as shown on page 7, are possible. The upper pole is used as N-conductor if required. The max. copper cross section of the conductor is 26 sqmm. If the cross section of the N-conductor is smaller than the cross section of the outer conductor adhere to regulation VDE 0100, part 430,.

Low voltages of max. 50 V AC or 120 V DC are valid if the conductor system is only used as control line (type...SSD). Refer to regulation SELV or PELV (also DIN VDE 0100-410). A ground conductor is required for higher voltages.

# TECHNICAL DATA

## APPLICATIONS

For mobile power consumers like cranes, monorails, electric hoists, machine tools, automated storage and retrieval systems, lighting systems.

## APPROVALS

UL-approved

## HOUSING

Color grey, plastic housing for 4 or 5 conductors.

Standard section 4 m. Other sections are available. The ground conductor is identified by international color code. Phase reversing prevented by design of the collector and housing. Higher number of conductors possible by combination of several conductor systems.

## COUPLINGS

Through plastic joint caps.

## FEED SETS

Through line feeds or end feeds.

When selecting the "overload" protection devices, selection has to be made according to DIN VDE 0100 part 530.

## END CAPS

The open ends of the conductor system are closed by end caps for KBHF and KBHS.

## HANGERS

Support bracket at the crane track (see page 9). Max. support distance of the conductor at following ambient temperatures:

- Indoor systems and roofed outdoor systems:  $\leq 35^{\circ}\text{C} = 2.00\text{ m}$
- Indoor and outdoor systems  
with and without heating:  $> 35^{\circ}\text{C} = 1.33\text{ m}$
- Cold storage  $\leq 0^{\circ}\text{C} = 1.33\text{ m}$

It is necessary to provide at least one additional hanger on the sections of the feeds (line feeds), removing sections, anti-condensation sections and expansion sections (1 m sections). This prevents any sagging of the conductor conductor system.

## EXPANSION DURING TEMPERATURE FLUCTUATION

The expansion sections are required to compensate the different expansions between copper conductors and steel- or concrete structures, in varying temperatures without interrupting electrical power. The different expansions between the plastic housing and the copper conductors will be compensated in every joint.

## ANTI-CONDENSATION SECTIONS

These sections are used for transfer of the Powerail to outdoor areas to avoid condensation. The conductor system is not separated electrically.

## CONTACT SECTIONS, TURNTABLES AND SWITCHES

Conductor sections for working areas and transfer applications see page 17 and 19.

## SECTIONALIZING

Conductor dead sections are electrical interrupts of the conductor. Under normal operating conditions a cross over with collectors to switch the voltage off or on is only allowed with low power ratings (control current). The conductors can be separated through air gaps (5 mm) or insulating pieces (35 mm). With the air gap the collector carbon bridges the gap, e.g. for mains. The insulating piece is longer than the carbon and each conductor section can be separated electrically, e.g. for control. Double isolating sections are recommended to guarantee safely separated conductor sections as per EN 60204.

## COLLECTORS

The current collectors are made of re-inforced polyester fiberglass, for high strength and light weight. Spring loaded carbon brushes maintain uniform contact. Connecting cables and hinged or flexible towing arms included.

The length of the connecting cable may not exceed 3 m if the added overload protection device is not designed for the load capacity of this cable. Refer also to regulation VDE 0100, part 430 and EN 60204-32. (Note: this occurs often with several collectors per system).

## CONTINUITY OF GROUND CONDUCTOR

The continuity of the ground conductor has to be guaranteed as per regulation EN60204-32 for conductor rails.

Runways of lifting devices may not be used as ground conductor, only an additional connection is permissible. Therefore a continuous ground conductor is required.

## WITH FOLLOWING SYSTEM REQUIREMENTS DOUBLE COLLECTORS HAVE TO BE USED

- as proper measure to fulfil the continuity of the ground conductor system via carbon brushes. Refer to regulation EN 60204-1-2007-06 and EN 60204-32-2009-03.
- Transfers with switches and turntables
- Operational voltage below 50 V
- low voltages, frequency controlled drives
- Transmission of data- and/or emergency stop signals
- high electrical loads

## REMOVING SECTION FOR COLLECTORS

Assembly and disassembly of the collector is possible at the end of the track as well as at the removing section. By opening and closing the slid-

## TECHNICAL DATA

ers at the bottom of the conductor housing the collector can be mounted and demounted easily. Before opening the removing section the conductor system has to be without voltage.

### SAFETY INSTRUCTIONS

It must be ensured that the arrangement of the conductor system provides minimum distances (0.5m) between fixed and mobile plant parts (i.e. between conductor rails, collector trolleys and towing arms) so as to avoid the risk of pinching.

### PLEASE NOTE

For use in galvanizing and pickling plants, under aggressive conditions and low voltage applications we would appreciate receiving detailed information, especially of the environmental conditions.

For quotations and order processing including conductor systems with curves, dead sections, turntables, switches etc. we require your drawings or sketches. Please use our questionnaire, page 28.

### CONDUCTOR SYSTEM VALUES: ELECTRICAL DATA

Type	Max. continuous current	Nominal voltage (UL)	Dielectric strength	Spec. resistance	Surface resistivity	Leakage resistance
KBH	200A (at 100% DC)	690 V (600 V)	IEC 60243-1-3 30–40 kV/mm	IEC 60093 5x1015 Ω/cm	IEC 60093 10 <sup>13</sup> Ω	EN 60112 CTI 400-2.7

### CONDUCTOR SYSTEM VALUES: MECHANICAL DATA

Type	Flexible strength	Tensile strength	Ambient temperature	Flammability	Resistance to chemicals (at 45 °C)
KBH	75 N/mm <sup>2</sup> ±10%	40 N/mm <sup>2</sup> ±10%	–30 °C up to +60 °C	flame retardant, self extinguishing, UL 94 V0	Gasoline, mineral oil, grease, acid sulfur up to 50%, caustic soda up to 50% and hydrochloric acid up to 25%, concentrated

### TEMPERATURE CORRECTION FACTOR $f_T$

Ambient temperature °C	35 °C	40 °C	45 °C	50 °C	55 °C	60 °C
Correction factor $f_T$ Standard shrouding	1	0.95	0.89	0.84	0.77	0.71

### VOLTAGE DROP FOR THE CONDUCTOR

For three-phase current  $\Delta U = \sqrt{3} \cdot I \cdot I_A \cdot Z$

Z = Impedance [Ω/km]

For alternating current  $\Delta U = 2 \cdot I \cdot I_A \cdot Z$

R = Resistance [Ω/km]

l = Feed length [km]

For direct current  $\Delta U = 2 \cdot I \cdot I_A \cdot R$

I<sub>A</sub> = Inrush current of installation in amperes

### PERMISSIBLE CONTINUOUS CURRENT OF THE CONDUCTOR

$$I_{Dzul,UT} = I_{zul} \cdot f_T[A] \text{ with } I_{Dzul,UT} > I_{DA}$$

I<sub>Dzul,UT</sub> = Permissible continuous current of the conductor at ambient temperature

I<sub>zul</sub> = Permissible continuous current of the conductor at 35 °C (catalogue value) [A]

f<sub>T</sub> = Correction factor

# TECHNICAL DATA

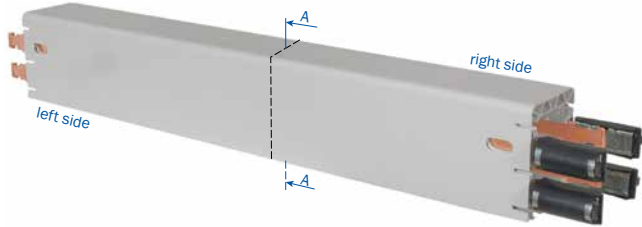

KBHF with spring loaded connectors

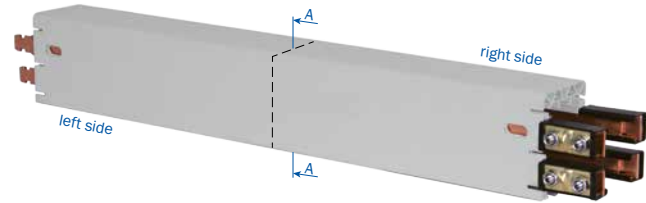

KBHS with bolted joints

Type <sup>(1)</sup> HS with PE SS without PE	Number of poles	Continuous current A at 35 °C <sup>(6)</sup>			Copper cross section mm <sup>2</sup>				Nominal voltage V <sup>(4)</sup>
		L1 L2 L3	60% DC	80% DC	100% DC	L1 L2 L3		N/5 <sup>(2)</sup>	
<b>KBHF</b>									
KBHF4/63-...HSC	4	81	70	63	3 x 10	10	-	-	690
KBHF4/63-...SSD <sup>(5)</sup>	4	81	70	63	-	-	-	4 x 10	690
KBHF4/80-...HSC	4	103	89	80	3 x 17	17	-	-	690
KBHF4/100-...HSC	4	129	112	100	3 x 26	26	-	-	690
KBHF5/63-...HSC	5	81	70	63	3 x 10	10	10	-	690
KBHF5/63-...SSD <sup>(5)</sup>	5	81	70	63	-	-	-	5 x 10	690
KBHF5/80-...HSC	5	103	89	80	3 x 17	17	17	-	690
KBHF5/100-...HSC	5	129	112	100	3 x 26	26	26 <sup>(3)</sup>	-	690
<b>KBHS</b>									
KBHS4/63-...HSC	4	81	70	63	3 x 10	10	-	-	690
KBHS4/63-...SSD <sup>(5)</sup>	4	81	70	63	-	-	-	4 x 10	690
KBHS4/80-...HSC	4	103	89	80	3 x 17	17	-	-	690
KBHS4/100-...HSC	4	129	112	100	3 x 26	26	-	-	690
KBHS4/125-...HSC	4	161	140	125	3 x 33	26	-	-	690
KBHS4/160-...HSC	4	207	179	160	3 x 51	26	-	-	690
KBHS4/200-...HSC	4	258	224	200	3 x 70	42	-	-	690
KBHS5/63-...HSC	5	81	70	63	3 x 10	10	10	-	690
KBHS5/63-...SSD <sup>(5)</sup>	5	81	70	63	-	-	-	5 x 10	690
KBHS5/80-...HSC	5	103	89	80	3 x 17	17	17	-	690
KBHS5/100-...HSC	5	129	112	100	3 x 26	26	26 <sup>(3)</sup>	-	690
KBHS5/125-...HSC	5	161	140	125	3 x 33	26	26 <sup>(3)</sup>	-	690
KBHS5/160-...HSC	5	207	179	160	3 x 51	26	26 <sup>(3)</sup>	-	690
KBHS5/200-...HSC	5	258	224	200	3 x 70	42	26 <sup>(3)</sup>	-	690

(1) ... Suffix types e.g. 2 m KBHF4/63-2000HSC, Order No. 600972, shorter lengths are made up from the next larger standard length.

(2) In case of using a conductor as N see page 3.

(3) 5th. Conductor max. 80A at 100% DC.

(4) Nominal voltage UL= 600V

(5) Control line

(6) Power consumption UL on request

## TECHNICAL DATA

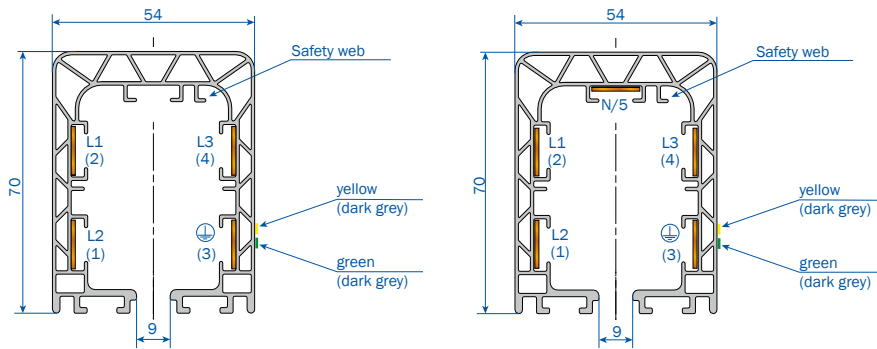

Numbers in paranthesis apply to control line

Leakage distance mm	Impedance at 50 Hertz and 20 °C $\Omega / 1000 \text{ m}$			Resistance at 20 °C $\Omega / 1000 \text{ m}$			Weight kg/m	Order No. <sup>(1)</sup>
	Phase		N	Phase		N		
33	1.728	1.728	-	1.717	1.717	-	1.304	600 97•
33	1.728	-	-	1.717	-	-	1.304	600 99•
33	1.074	1.074	-	1.057	1.057	-	1.536	600 98•
33	0.712	0.712	-	0.687	0.687	-	1.864	600 02•
33	1.728	1.728	1.728	1.717	1.717	1.717	1.410	601 00•
33	1.728	-	1.728	1.717	-	1.717	1.410	601 02•
33	1.074	1.074	1.074	1.057	1.057	1.057	1.700	601 01•
33	0.712	0.712	0.712	0.687	0.687	0.687	2.110	600 12•
33	1.782	1.728	-	1.717	1.717	-	1.424	601 03•
33	1.728	-	-	1.717	-	-	1.424	601 05•
33	1.074	1.074	-	1.057	1.057	-	1.656	601 04•
33	0.712	0.712	-	0.687	0.687	-	1.984	600 06•
33	0.579	0.712	-	0.549	0.687	-	2.161	600 07•
30	0.383	0.712	-	0.344	0.687	-	2.699	600 08•
27	0.299	0.457	-	0.254	0.429	-	3.297	600 31•
33	1.728	1.728	1.728	1.717	1.717	1.717	1.560	601 06•
33	1.728	-	1.728	1.717	-	1.717	1.560	601 08•
33	1.074	1.074	1.074	1.057	1.057	1.057	1.850	601 07•
33	0.712	0.712	0.712	0.687	0.687	0.687	2.260	600 16•
33	0.579	0.712	0.712	0.549	0.687	0.687	2.437	600 17•
30	0.383	0.712	0.712	0.344	0.687	0.687	2.926	600 18•
27	0.299	0.457	0.457	0.254	0.429	0.687	3.573	600 32•

• The last number of the order specifies the section length. Please suffix the order number with 1, 2, 3, 4.

Ground = PE

## JOINTING MATERIAL, HANGERS & END CAPS

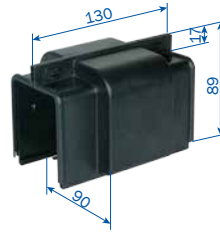

### JOINT CAP, SELF LOCKING

Joint cap ready installed

Type	Weight kg	Order No.
VM-KVM	0.116	600005



### SLIDING HANGER

Sliding hanger at conductor section

Type <sup>(1)</sup>	Weight kg	Order No.
AH-KGA	0.129	600000
AH-KGA/K	0.129	600397



### FIXPOINT HANGER

Fixpoint hanger at conductor section

Type <sup>(1)</sup>	Weight kg	Order No.
AH-KFA	0.160	600007
AH-KFA/K	0.177	600398

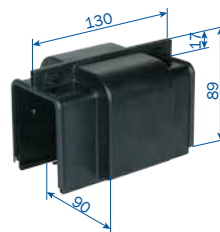

### END CAP – LEFT AND RIGHT VERSION

End cap ready installed

Type	Weight kg	Order No.
EK-KE	0.150	600008

(1) ... / K with stainless screws  
All steel metal components



# BRACKETS

## VIEW WITHOUT I-BEAM

### FIXING CLAW SUITABLE FOR D = 6 – 15 MM

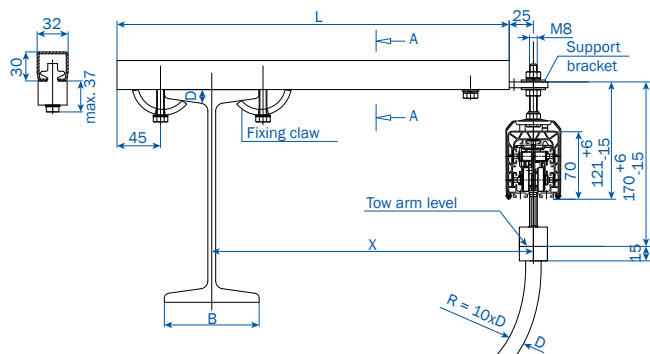

### FIXING CLAW SUITABLE FOR D = 15 – 25 MM

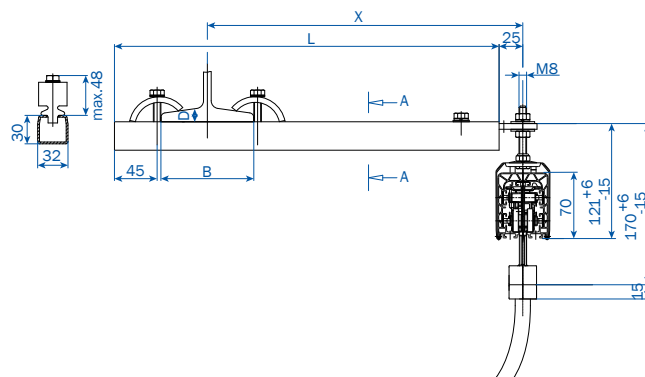

### ARRANGEMENT EHK WITH SMALL FIXING CLAW

Attention! Make sure that hoist wheels have enough clearance.

Use small claw if necessary.

Select next larger size bracket when your I-beam dimension B is more than 170 up to 300 mm

□-rail of EHK is identical to type S 1, Cat. 8a

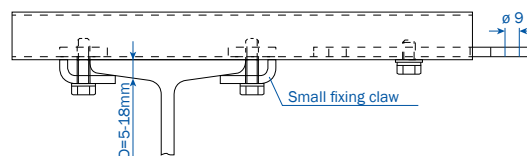

Type <sup>(1)</sup>	X mm	L mm	B max mm	Weight kg	Order No.	
					standard version	small fixing claw <sup>(1)</sup>
HK-EHK250-NS	250	350	170	1.080	251600	-
HK-EHK250-KS...					-	251720-...
HK-EHK300-NS	300	400	170	1.128	251610	-
HK-EHK300-KS...					-	251730-...
HK-EHK400-NS	400	500	170	1.266	251620	-
HK-EHK400-KS...					-	251740-...
HK-EHK500-NS	500	600	170	1.394	251630	-
HK-EHK500-KS...					-	251750-...
HK-EHK600-NS	600	700	170	1.561	251640	-
HK-EHK600-KS...					-	251760-...
HK-EHK700-NS	700	800	170	1.761	251650	-
HK-EHK700-KS...					-	251770-...
HK-EHK750-NS	750	850	170	1.782	251660	-
HK-EHK750-KS...					-	251780-...
HK-EHK800-NS	800	900	170	1.936	251670	-
HK-EHK800-KS...					-	251790-...

(1) e.g. HK-EHK250-KS12 → Order-No. 251720-12 for fixing claw with D = 12 mm  
Select next larger size bracket when your I-beam dimension B is more than 170 mm.

## END FEEDS, LINE FEEDS

### END FEED (UP TO 80 A)

End feed comes loose without conductor section.

It can be mounted at the left or right hand side.

Electrical connection with customer supplied cable shoes to M6 terminals.

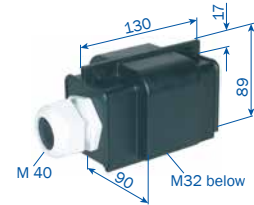

Type	Weight kg	Cable gland (Dimensions see page 13)	Order No.
ES-KKE4/63-80HS	0.271	M 40	600010
ES-KKE5/63-80HS	0.288	M 40	600107
ES-KKE4/63SS	0.252	M 25	600015
ES-KKE5/63SS	0.265	M 25	600108

### END FEED (UP TO 100 A)

End feed comes loose without conductor section.

It can be mounted at the left or right hand side.

Electrical connection with customer supplied cable shoes to M6 terminals.



Type	Weight kg	Cable gland (Dimensions see page 13)	Order No.
ES-KKE4/63-100HS	0.613	M 32 or M 50 <sup>(1)</sup>	600422
ES-KKE5/63-100HS	0.646	M 32 or M 50 <sup>(1)</sup>	600423

### LINE FEED (AT JOINT, 63 A)

KSE type comes loose without conductor section.

It can be mounted at any joint.

Electrical connection with customer supplied cable shoes to M6 terminals.

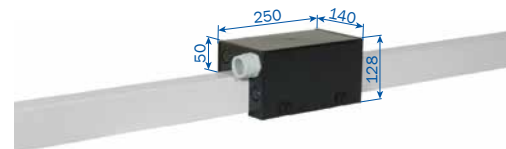

Type	Weight kg	Cable gland (Dimensions see page 13)	Order No.
ES-KSE4/63HS-L	0.806	M 32	600035
ES-KSE5/63HS-L	0.866	M 32	600038
ES-KSE4/63SS-L	0.785	M 25	600028
ES-KSE5/63SS-L	0.843	M 25	600029

### LINE FEED (AT JOINT, 80-100 A)

KSE type comes loose without conductor section.

It can be mounted at any joint.

Electrical connection with customer supplied cable shoes to M6 terminals.

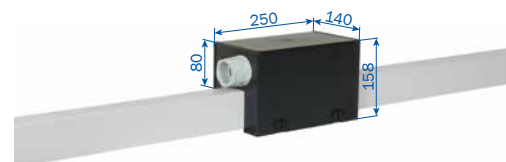

Type	Weight kg	Cable gland (Dimensions see page 13)	Order No.
ES-KSE4/80-100HS-L	0.936	M 50	600036
ES-KSE5/80-100HS-L	0.996	M 50	600039

Feeds in the curve area on request.

(1) Both cable glands are attached to the packing unit.

## LINE FEEDS

### LINE FEED (INCL. 1 M SECTION, 63–100 A)

With spring loaded connector.

Electrical connection with customer supplied cable shoes to M6 terminals.

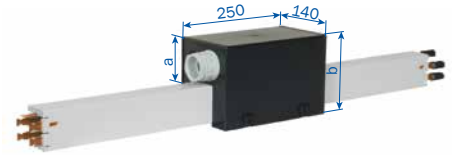

Type	Weight kg	Dimension		Cable gland (Dimensions see page 13)	Order No.
		a	b		
ES-KEF4/63HSC-1000	2.066	50	128	M 32	600975
ES-KEF4/80HSC-1000	2.428	80	158	M 50	600976
ES-KEF5/63HSC-1000	2.232	50	128	M 32	600977
ES-KEF5/80HSC-1000	2.652	80	158	M 50	600978
ES-KEF4/100HSC-1000	2.756	80	158	M 50	600201
ES-KEF5/100HSC-1000	3.062	80	158	M 50	600209
ES-KEF4/63SSD-1000	2.046	50	128	M 25	600979
ES-KEF5/63SSD-1000	2.210	50	128	M 25	600980

### LINE FEED (INCL. 1 M SECTION, 63–125 A)

With bolted joints.

Electrical connection with customer supplied cable shoes M6 terminals to 100 A, with M8 terminals to 125 A.

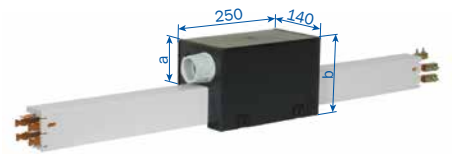

Type	Weight kg	Dimension		Cable gland (Dimensions see page 13)	Order No.
		a	b		
ES-KES4/63HSC-1000	2.190	50	128	M 32	600985
ES-KES4/80HSC-1000	2.552	80	158	M 50	600986
ES-KES5/63HSC-1000	2.387	50	128	M 32	600987
ES-KES5/80HSC-1000	2.807	80	158	M 50	600988
ES-KES4/100HSC-1000	2.880	80	158	M 50	600225
ES-KES4/125HSC-1000	3.222	80	158	M 50	600045
ES-KES5/100HSC-1000	3.217	80	158	M 50	600233
ES-KES5/125HSC-1000	3.621	80	158	M 50	600049
ES-KES4/63SSD-1000	2.170	50	128	M 25	600989
ES-KES5/63SSD-1000	2.365	50	128	M 25	600990

## LINE FEED & TERMINAL BOX

### LINE FEED

including 1 m section (125 – 200A) with 2 m single cores  
Electrical connection with customer supplied cable shoes  
to M6 terminals. See below.

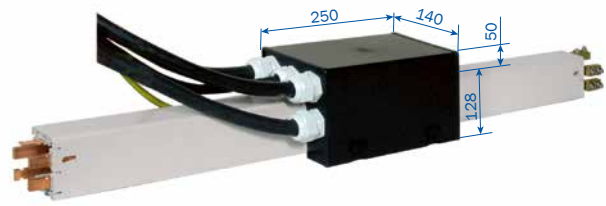

Type	Weight kg	Cable cross section in mm <sup>2</sup> / Ø in mm			Order No.
		L1-L3	Ground	N / 5	
ES-KELS4/125HSC-1000-2	7.803	35 / 16	25 / 10	-	600069
ES-KELS4/160HSC-1000-2	9.690	50 / 18	25 / 10	-	600075
ES-KELS4/200HSC-1000-2	11.668	70 / 21	35 / 11	-	600385
ES-KELS5/125HSC-1000-2	9.150	35 / 16	25 / 10	25 / 15	600077
ES-KELS5/160HSC-1000-2	11.037	50 / 18	25 / 10	25 / 15	600079
ES-KELS5/200HSC-1000-2	13.014	70 / 21	35 / 11	25 / 15	600387

### TERMINAL BOX (FOR KELS, 125–200 A)

Electrical connection with customer supplied cable shoes.  
Clamping range 16 – 95 mm<sup>2</sup>.  
View "A" Input of the single cores of the KELS (a. m.)  
View "B" with M 63 (Dimensions see page 13)

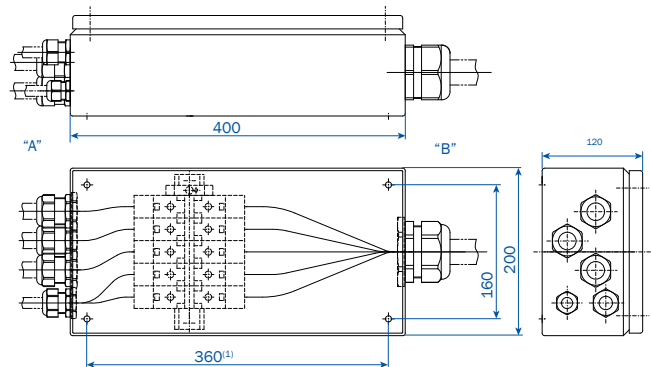

Type	Weight kg	For feed line	Order No.
ES-ZK1	5.228	ES-KELS4/125HSC-1000-2	600389
ES-ZK2	5.276	ES-KELS4/160HSC-1000-2 and ES-KELS4/200HSC-1000-2	600390
ES-ZK3	5.595	ES-KELS5/125HSC-1000-2	600391
ES-ZK4	5.645	ES-KELS5/160HSC-1000-2 and ES-KELS5/200HSC-1000-2	600392

Feeds in the bow area on request.

(1) Fixing borings ø 7 mm at the bottom of the box.

# CURVES, SEALING STRIP & CABLE GLANDS FOR FEEDS

## CURVES

### PRODUCTION CORRESPONDING TO CUSTOMER DRAWING

Min. horizontal bending radius	63-125 A	= 600 mm
	160 A	= 1000 mm
	200 A	= on request

max.  $\sphericalangle$  120°

min. bending radius, vertical = 2000 mm

max. curved length = 3600 mm

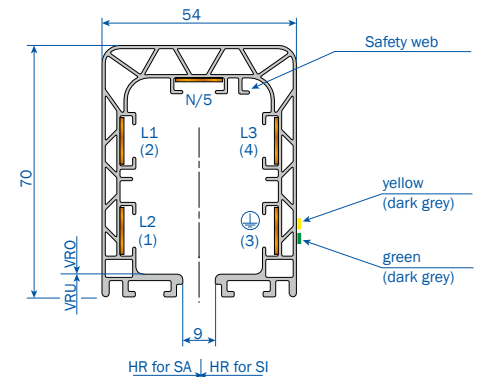

### HORIZONTAL CURVE FOR SI AND SA

SI = Safety-web inside

SA = Safety web outside

### VERTICAL CURVE FOR VRO AND VRU

VRO = Vertical radius upwards

VRU = Vertical radius downwards

Safety web will be mounted in direction of track.

Changes in measurements of curves have to be mentioned for replacement orders.

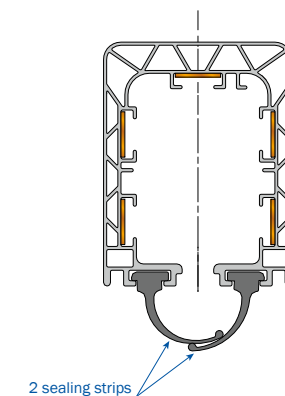

## SEALING STRIP (INCLUDING ACCESSORIES)

Type	Description	Order No.
DL-D-KBH-MKH-MKL-TDV	Sealing strip <sup>(1)</sup>	600551
DL-F-KBH	Fixing clamp for sealing strip (1 per end)	600354
DL-V-KSLT-KBH-MKL/H-LSV/G	Coupling for sealing strip (2 for each joint)	258300
DL-EZRD-KBH	Mounting glider for sealing strip	600109
SA-ZB-DG-KSW-S	Sealing strip slide plate for collectors KSW	600640

## CABLE GLANDS FOR FEEDS

For Type	Cable gland	For cable diam. in mm	Power rating in A	Page
ES-KKE ...	M50	27-35	63-100 HS	10
ES-KKE ...	M40	17-28	63/80 HS	10
ES-KKE ...	M32	15-21	63 SS	10
ES-KSE/KEF/KES...	M32	17-26	63 HS	10 and 11
ES-KSE/KEF/KES...	M50	23-34	80-100 HS	10 and 11
ES-KES...	M50	29-40	125 HS	11
ES-ZK1-4... (Page B)	M63	27-48	125/160/200 HS	12
BH-AKB-KBH...	M25	9-19	-	15
ES-KKE/KSE/KEF/KES...	M25	9-19	63SS	10 and 11

(1) The max. single length is 40 m long. For further distances are joint laces necessary.  
For each meter system length have 2 m sealing strip to be ordered. The delivery will be in pairs.

# HEATING

## HEATING CABLE

Type	Resistance <sup>(1)</sup>	Order No.
HL-0.10-EYCEX-5203-PTFE-260-750	0.10 Ω/m	196381
HL-0.15-EYCEX-5203-PTFE-260-750	0.15 Ω/m	196382
HL-0.20-EYCEX-5203-PTFE-260-750	0.20 Ω/m	196383
HL-0.32-EYCEX-5203-PTFE-260-750	0.32 Ω/m	196384
HL-0.38-EYCEX-5203-PTFE-260-750	0.38 Ω/m	196385
HL-0.48-EYCEX-5203-PTFE-260-750	0.48 Ω/m	196386
HL-0.60-EYCEX-5203-PTFE-260-750	0.60 Ω/m	196387
HL-0.81-EYCEX-5203-PTFE-260-750	0.81 Ω/m	196389
HL-1.00-EYCEX-5203-PTFE-260-750	1.00 Ω/m	196390
HL-1.44-EYCEX-5203-PTFE-260-750	1.44 Ω/m	196391
HL-2.00-EYCEX-5203-PTFE-260-750	2.00 Ω/m	196392
HL-3.00-EYCEX-5203-PTFE-260-750	3.00 Ω/m	196393
HL-4.00-EYCEX-5203-PTFE-260-750	4.00 Ω/m	196394
HL-4.40-EYCEX-5203-PTFE-260-750	4.40 Ω/m	196395
HL-5.16-EYCEX-5203-PTFE-260-750	5.16 Ω/m	196396
HL-5.60-EYCEX-5203-PTFE-260-750	5.60 Ω/m	196397

<sup>(1)</sup> Tolerance ±2.5%

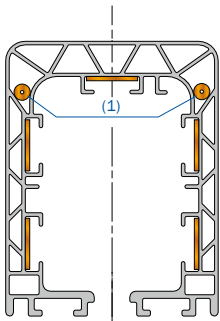

<sup>(2)</sup> Arrangement of the heating cables on both sides.

We recommend a heating system for outdoor installations and conductor systems in humid plants. The heating consists of two heating cables which are arranged according to the illustration beside.

Attention: Switch on heating system below +5 °C ambient temperature.

The type of heating cable has to be calculated: heat output per heating cable between 20 – 25 W/m.

For longer heating distances the total length has to be divided into different heating sections. For shorter heating distances to feed with lower secondary voltage via transformer.

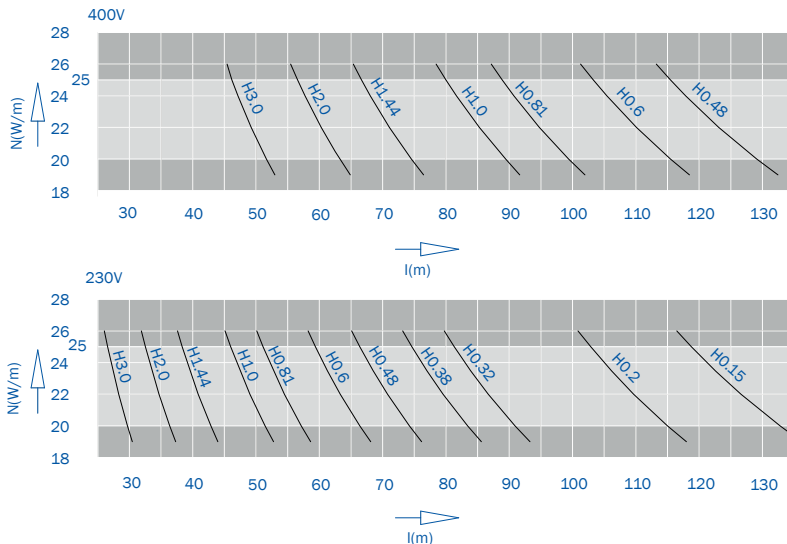

$$\text{Heating capacity Watt/m: } N' = \frac{U^2}{R \cdot L^2}$$

U = Supply voltage (Volt)

R = Resistance of heating cable (Ohm/m)

L = Length of heating section (m)

# HEATING

## LAYOUT EXAMPLES (DEPENDING ON SYSTEM SITUATION)

a) 2 heating circuits

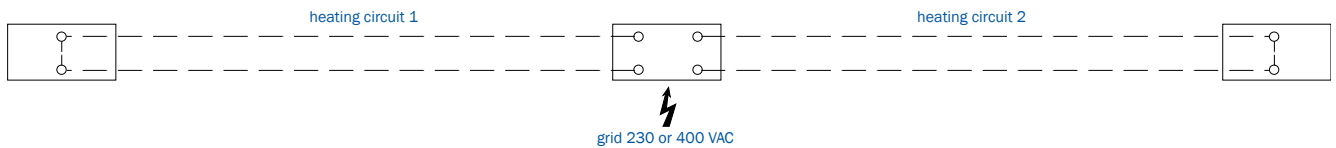

b) 1 heating circuit

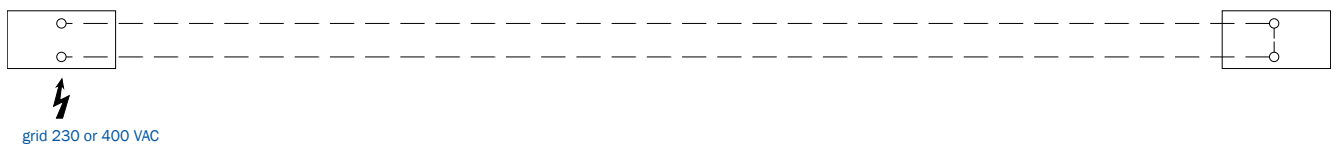

c) 2 heating circuits

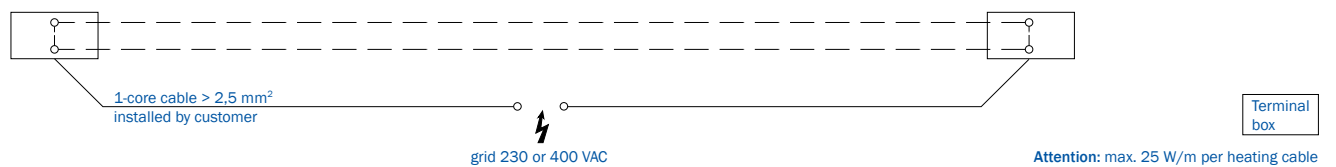

## TERMINAL BOXES FOR HEATING

Type	Version	Cable gland Measurements see page 13	Order No.
BH-AKB-KBH-L	left end	M25	600155
BH-AKB-KBH-R	right end	M25	600156
BH-AKB-KBH-M	line feed	2 x M25	600065
BH-MA-KBH-MKL/H-LSV/G	1 set material for connecting clamps		195291

For each end feed box 2 sets of material for connecting ends are required.

For line feed you need 4 sets of material for connection ends.

Order for 60 m powerail – example c)

1) 122 m heating cable type H 2.0 (2x60 m and 2x1 m additional)

Voltage 400 V, two heating circles parallel

heating capacity as per above mentioned diagramm

2x 22 W/m at 60 m 2x 22 W/m ~2640 W = 2,64 kW.

2) 1x junction box left end, 1x junction box right end

3) 4x sets of material for connection ends.

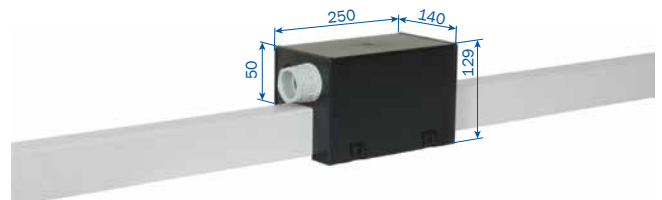

Switch gear assembly and temperature control unit as per customers inquiry.

Fuses, cables etc. have to be provided by the customer.

# CONTACT SECTIONS, TURNTABLES & SWITCHES

## CONTACT SECTION<sup>(1)</sup>

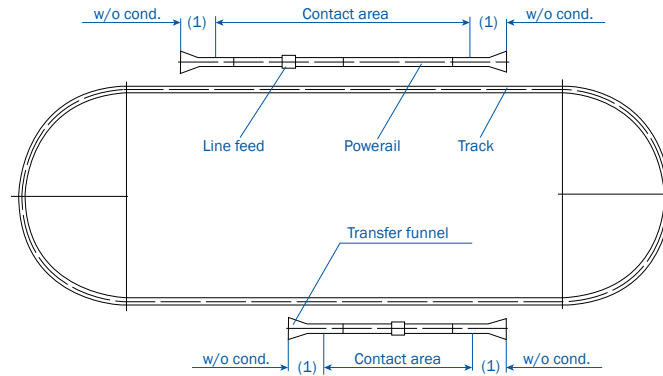

## TURNTABLE

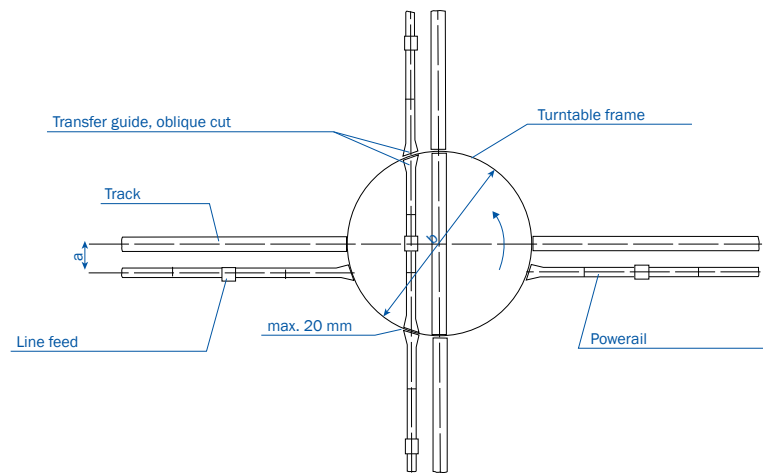

## SWITCH

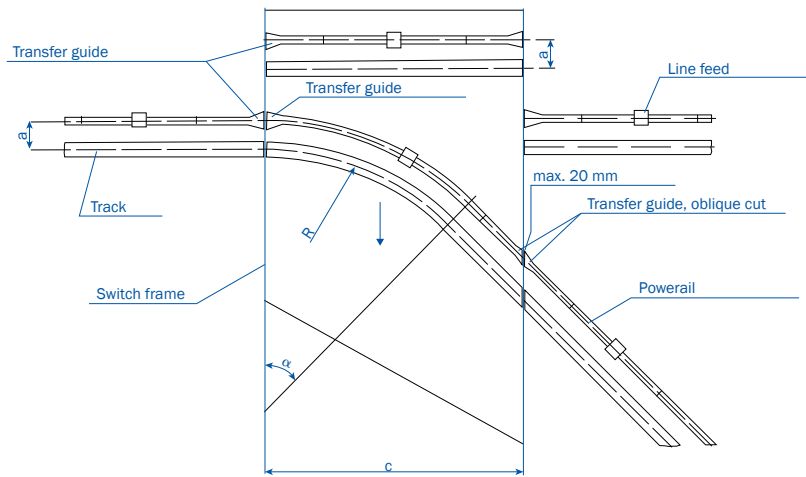

Please submit drawings of transfer applications.

Specify dimensions a, b, c, R and angle  $\alpha$ .

$\alpha = 50^\circ$

Max. 20 mm air gap between transfer guides.

To create all parts for contact sections, turntables and switches we require detailed construction drawings.

(1) Contact sections must not be activated before collectors are fully engaged.



# TRANSFER FUNNELS

## TRANSFER FUNNEL

Conductor system should not be activated before the collectors carbons have complete contact with the conductors.

Offset:

- max. 10 mm horizontal
- max. 10 mm vertical

Max. speed for crossover of the current collector 60 m/min.

Hints for dimensioning the left-and right hand version refer to page 6 and 7.

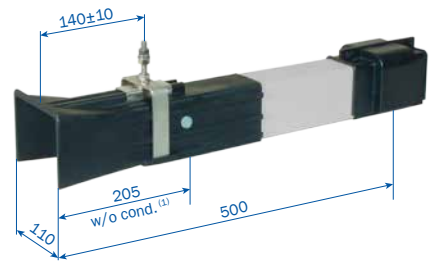

Type	Weight kg	Order No.	
		Left version	Right version
ET-KET4/63-125-L-HSC-500 <sup>(2)</sup>	1.552	600285	-
ET-KET4/63-125-R-HSC-500 <sup>(2)</sup>	1.493	-	600279
ET-KET4/160-L-HSC-500	1.636	600286	-
ET-KET4/160-R-HSC-500	1.562	-	600280
ET-KET4/200-L-HSC-500	1.786	600305	-
ET-KET4/200-R-HSC-500	1.688	-	600303
ET-KET5/63-125-L-HSC-500 <sup>(2)</sup>	1.702	600288	-
ET-KET5/63-125-R-HSC-500 <sup>(2)</sup>	1.632	-	600282
ET-KET5/160-L-HSC-500	1.784	600289	-
ET-KET5/160-R-HSC-500	1.701	-	600283
ET-KET5/200-L-HSC-500	1.934	600306	-
ET-KET5/200-R-HSC-500	1.823	-	600304
ET-KET4/63-L-SSD-500 <sup>(2)</sup>	1.524	600287	-
ET-KET4/63-R-SSD-500 <sup>(2)</sup>	1.524	-	600281
ET-KET5/63-L-SSD-500 <sup>(2)</sup>	1.524	600290	-
ET-KET5/63-R-SSD-500 <sup>(2)</sup>	1.524	-	600284

(1) Corresponding to the center of collector

(2) Also suitable for former 40 A-version

# TRANSFER GUIDES

## TRANSFER GUIDES, STRAIGHT

Necessary with all types of double collectors or 2 single collectors.

Staggered arrangement of the transfer guides to each other:

- max. 5 mm horizontal
- max. 3 mm vertical

Max. speed for crossover of the current collector 80 m/min.

Hints for dimensioning the left-and right hand version refer to page 6 and 7.

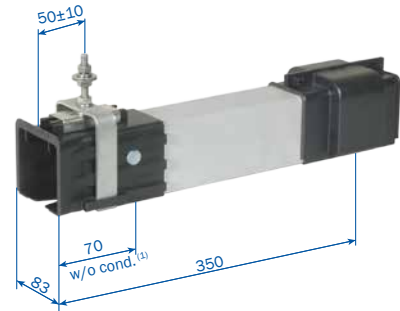

Type	Weight kg	Order No.	
		Left version	Right version
UE-KÜ4/63-125-L-HSC-350 <sup>(2)</sup>	1.276	600261	-
UE-KÜ4/63-125-R-HSC-350 <sup>(2)</sup>	1.276	-	600255
UE-KÜ4/160-L-HSC-350	1.351	600262	-
UE-KÜ4/160-R-HSC-350	1.351	-	600256
UE-KÜ4/200-L-HSC-350	1.490	600309	-
UE-KÜ4/200-R-HSC-350	1.490	-	600307
UE-KÜ5/63-125-L-HSC-350 <sup>(2)</sup>	1.434	600264	-
UE-KÜ5/63-125-R-HSC-350 <sup>(2)</sup>	1.434	-	600258
UE-KÜ5/160-L-HSC-350	1.509	600265	-
UE-KÜ5/160-R-HSC-350	1.509	-	600259
UE-KÜ5/200-L-HSC-350	1.648	600310	-
UE-KÜ5/200-R-HSC-350	1.648	-	600308
UE-KÜ4/63-L-SSD-350 <sup>(2)</sup>	1.276	600263	-
UE-KÜ4/63-R-SSD-350 <sup>(2)</sup>	1.276	-	600257
UE-KÜ5/63-L-SSD-350 <sup>(2)</sup>	1.427	600266	-
UE-KÜ5/63-R-SSD-350 <sup>(2)</sup>	1.427	-	600260

(1) Corresponding to the center of collector  
 (2) Also suitable for former 40A-version

# TRANSFER GUIDES & CONDUCTOR DEAD SECTION

## TRANSFER GUIDES, OBLIQUE

Necessary with all types of double collectors or 2 single collectors.

Staggered arrangement of the transfer guides to each other:

- max. 5 mm horizontal
- max. 3 mm vertical

Measurements (oblique) and angle to be specified by customer

Max. speed for crossover of the current collector 80 m/min.

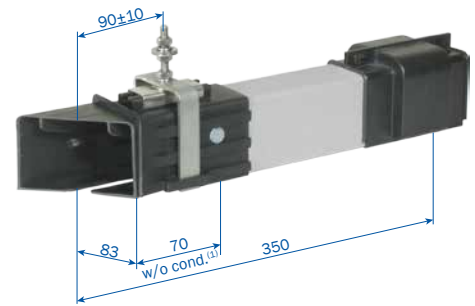

Hints for dimensioning the left-and right hand version refer to page 6 and 7.

Type <sup>(1)</sup>	Weight kg	Order No.	
		Left version	Right version
UE-KÜS4/63-125-L-HSC-350 <sup>(2)</sup>	1.243	600273	-
UE-KÜS4/63-125-R-HSC-350 <sup>(2)</sup>	1.243	-	600267
UE-KÜS4/160-L-HSC-350	1.324	600274	-
UE-KÜS4/160-R-HSC-350	1.324	-	600268
UE-KÜS4/200-L-HSC-350	1.517	600317	-
UE-KÜS4/200-R-HSC-350	1.517	-	600315
UE-KÜS5/63-125-L-HSC-350 <sup>(2)</sup>	1.381	600276	-
UE-KÜS5/63-125-R-HSC-350 <sup>(2)</sup>	1.381	-	600270
UE-KÜS5/160-L-HSC-350	1.447	600277	-
UE-KÜS5/160-R-HSC-350	1.447	-	600271
UE-KÜS5/200-L-HSC-350	1.668	600318	-
UE-KÜS5/200-R-HSC-350	1.668	-	600316
UE-KÜS4/63-L-SSD-350 <sup>(2)</sup>	1.243	600275	-
UE-KÜS4/63-R-SSD-350 <sup>(2)</sup>	1.243	-	600269
UE-KÜS5/63-L-SSD-350 <sup>(2)</sup>	1.379	600278	-
UE-KÜS5/63-R-SSD-350 <sup>(2)</sup>	1.379	-	600272

## CONDUCTOR DEAD SECTION

Please advise us which conductors should be disconnected (see page 6 and 7).

The dead section comes factory assembled.

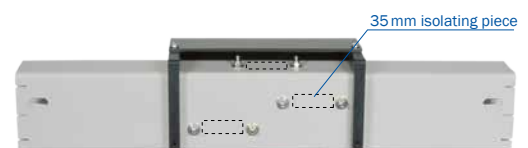

Picture shows a isolating piece.

Air gap 5 mm		Isolating piece 35 mm	
Type <sup>(3)</sup>	Order No.	Type	Order No.
ST-KTL1 ...	600298	ST-KTI1 ...	600293
ST-KTL2 ...	600299	ST-KTI2 ...	600294
ST-KTL3 ...	600300	ST-KTI3 ...	600295
ST-KTL4 ...	600301	ST-KTI4 ...	600296
ST-KTL5 ...	600302	ST-KTI5 ...	600297

(1) Corresponding to the center of collector

(2) Also suitable for former 40 A-version

(3) Complete types e.g. ST-KTI3HS-L1/L2/L3-KSW for a 35 mm isolating piece with separation of conductors L1, L2, L3 and 2 for the current collector KSW  
→ Order-No.: 600295

## REMOVING SECTION

### REMOVING SECTION (INCL. 1 M CONDUCTOR SECTION)

with special bolted joints for KBHF and KBHS on both ends.

Assembly and disassembly of the collector is possible at the end of the track as well as at the removing section.

By opening and closing the sliders at the bottom of the removing section housing the collector can be mounted and demounted easily.

Before opening disconnect mains. The removing section does not disconnect the conductor system electrically.

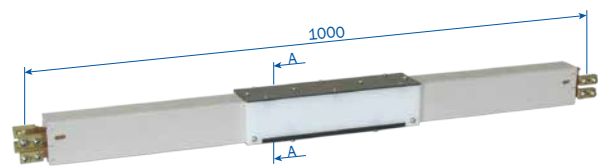
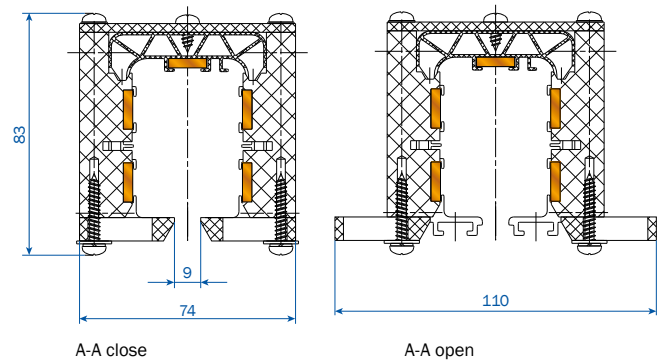

### FOR SINGLE COLLECTORS

Type	Weight kg	Order No.
AT-KAT4/63-125HSC-1000 <sup>(1)</sup>	3.507	600165
AT-KAT4/160HSC-1000	3.763	600166
AT-KAT4/200HSC-1000	4.260	600327
AT-KAT5/63-125HSC-1000 <sup>(1)</sup>	3.957	600167
AT-KAT5/160HSC-1000	4.213	600168
AT-KAT5/200HSC-1000	4.710	600328
AT-KAT4/63SSD-1000 <sup>(1)</sup>	3.449	600169
AT-KAT5/63SSD-1000 <sup>(1)</sup>	3.899	600170

### FOR DOUBLE COLLECTORS

Type	Weight kg	Order No.
AT-KATD4/63-125HSC-1000 <sup>(1)</sup>	4.330	600175
AT-KATD4/160HSC-1000	4.566	600176
AT-KATD4/200HSC-1000	5.050	600329
AT-KATD5/63-125HSC-1000 <sup>(1)</sup>	4.780	600177
AT-KATD5/160HSC-1000	5.015	600178
AT-KATD5/200HSC-1000	5.501	600330
AT-KATD4/63SSD-1000 <sup>(1)</sup>	4.312	600179
AT-KATD5/63SSD-1000 <sup>(1)</sup>	4.762	600180

(1) Also suitable for former 40 A-version

## MAINTENANCE SECTIONS

For maintenance work with KBH systems, collector removal and conductor bar replacement can be easily and quickly achieved with a maintenance section. Maintenance sections conveniently drop out or reinstall at existing runway installations. To obtain best possible accessibility at longer runways we recommend installing several maintenance repair sections at convenient intervals or locations.

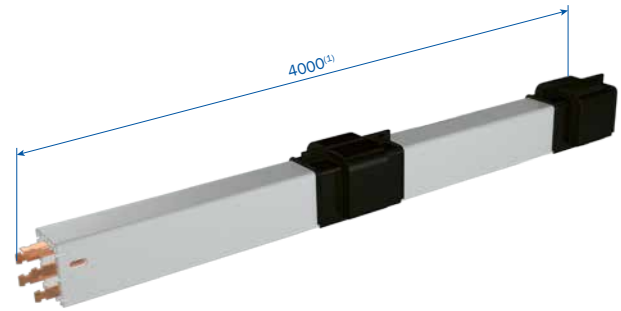

Type	Weight kg	Order No.
RVT-KRT4/63-4000HSC	5.534	601005
RVT-KRT5/63-4000HSC	5.953	601007
RVT-KRT4/80-4000HSC	6.462	601006
RVT-KRT5/80-4000HSC	7.113	601008
RVT-KRT4/100-4000HSC	7.774	600811
RVT-KRT5/100-4000HSC	8.753	600812
RVT-KRT4/125-4000HSC	8.482	600813
RVT-KRT5/125-4000HSC	9.461	600814
RVT-KRT4/160-4000HSC	10.438	600816
RVT-KRT5/160-4000HSC	11.417	600817
RVT-KRT4/200-4000HSC	13.016	600801
RVT-KRT5/200-4000HSC	13.994	600802
RVT-KRT4/63-4000SSD	5.534	601009
RVT-KRT5/63-4000SSD	5.953	601010

(1) Standard length = 4000 mm; other lengths and also maintenance sections in curves ( $R_{min} = 1000 \text{ mm} / L_{min} = 1000 \text{ mm}$ ) on request.

# ANTI-CONDENSATION SECTION

## ANTI-CONDENSATION SECTION

with special bolted joints for KBHF and KBHS at both ends.

## APPLICATION OF ANTI-CONDENSATION SECTION

The anti-condensation section will be used where conductor systems are passing from indoor to outdoor, preventing condensation of the outside mounted conductor section. The warm air from indoors can escape through the anti condensation section (see sketch). The anti-condensation section does not interrupt the conductor system electrically.

Additional feeds are not required.

## ASSEMBLY

The anti-condensation section is to be placed directly (0.5 m – 1 m max.) at the transfer point from indoor to outdoor (see sketch).

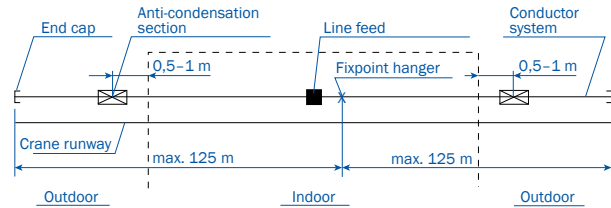
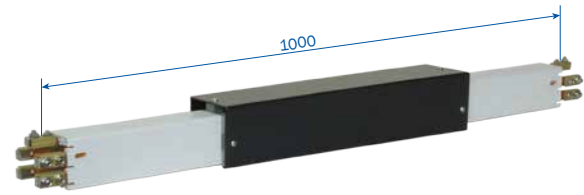

Type	Weight kg	Order No.
BT-KBT4/63-125HSC-1000 <sup>(1)</sup>	3.573	600185
BT-KBT4/160HSC-1000	3.843	600186
BT-KBT4/200HSC-1000	4.358	600319
BT-KBT5/63-125HSC-1000 <sup>(1)</sup>	3.805	600188
BT-KBT5/160HSC-1000	4.075	600189
BT-KBT5/200HSC-1000	4.590	600320
BT-KBT4/63SSD-1000 <sup>(1)</sup>	3.573	600187
BT-KBT5/63SSD-1000 <sup>(1)</sup>	3.805	600190

(1) Also suitable for former 40A-version

# EXPANSION SECTION

## EXPANSION SECTION

The Expansion sections are required to compensate the different expansions between copper conductors and steel- or concrete structures, in varying temperatures without interrupting electrical power.

Expansion joints are used when the conductor length between feeds, curves, switches or other fix points is exceeding 20 m.

Max. length during differences in temperature:

$\Delta t$  90 °C (–30 °C up to +60 °C)

Install one expansion joint per 100 m.

An additional expansion joint every 100 m.

Arrangement of fixpoints according to sketches.

The remaining conductor sections have to be arranged in sliding hangers. Additional feeds or current collectors are not required as the expansion-sections do not interrupt electrical power.

## ASSEMBLY

The gap dimension "a" is 75 mm and is valid for an ambient temperature of –10 °C to +35 °C during installation.

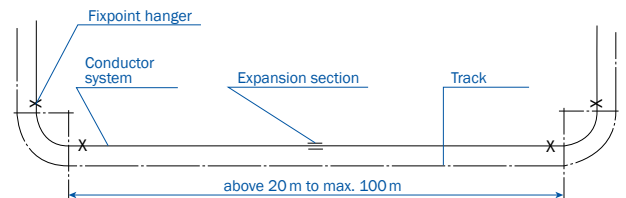
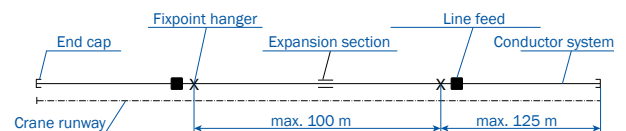
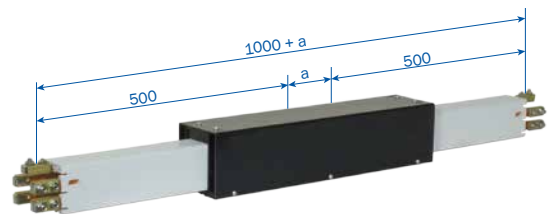

Type	Weight kg	Order No.
DT-KD4/63-125HSC-1000 <sup>(1)</sup>	4.540	600135
DT-KD4/160HSC-1000	4.752	600136
DT-KD4/200HSC-1000	5.034	600325
DT-KD5/63-125HSC-1000 <sup>(1)</sup>	5.014	600138
DT-KD5/160HSC-1000	5.218	600139
DT-KD5/200HSC-1000	5.508	600326
DT-KD4/63SSD-1000 <sup>(1)</sup>	4.540	600137
DT-KD5/63SSD-1000 <sup>(1)</sup>	5.014	600140

(1) Also suitable for former 40A-version

# SINGLE CURRENT COLLECTOR

## COLLECTOR KSW

max. speed 150 m/min.

For conductor systems with sealing strip up to 100 m/min.

## CONNECTING CABLE

for 25 A with 2.5 mm<sup>2</sup> / core

for 40 A with 4.0 mm<sup>2</sup> / core

for 60 A with 6.0 mm<sup>2</sup> / core

1 m long, longer cables on request.

Cleaning collector on request

Order example for a 2 m long cable

Order-No. 600096-2 for collector SA-KSW4/40-2HS28-60

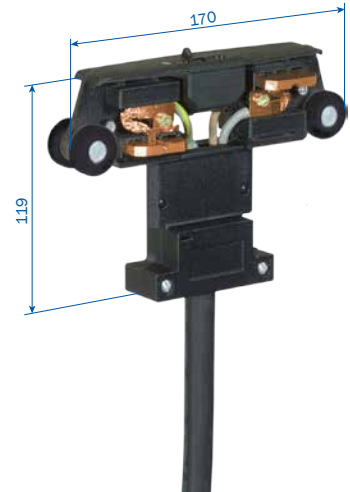

Type	Weight kg	Number of poles	Power rating at 60% DC in A	Approx. diameter of connecting-cables in mm	Order No.
SA-KSW4/25-1HS28-60	0.552	4	25	13.0	600095
SA-KSW4/40-1HS28-60	0.656	4	40	15.0	600096
SA-KSW4/60-1HS28-40	0.797	4	60 <sup>(1)</sup>	17.0	600066
SA-KSW5/25-1HS28-60	0.634	5	25	14.0	600098
SA-KSW5/40-1HS28-60	0.771	5	40	17.0	600099
SA-KSW5/60-1HS28-40	0.945	5	60 <sup>(1)</sup>	19.0	600413
SA-KSW4/25-1SS28-60	0.472	4	25	11.0	600097
SA-KSW5/25-1SS28-60	0.534	5	25	12.0	600100

## COLLECTOR KSWs

max. speed 250 m/min.

For conductor systems with sealing strip up to 100 m/min.

## CONNECTING CABLE

for 25 A with 2.5 mm<sup>2</sup> / core

for 40 A with 4.0 mm<sup>2</sup> / core

for 60 A with 6.0 mm<sup>2</sup> / core

1 m long, longer cables on request.

Order example for a 2 m long cable

Order-No. 600149-2 for collector SA-KSWS5/40-2HS28-60



Type	Weight kg	Number of poles	Power rating at 60% DC in A	Approx. diameter of connecting-cables in mm	Order No.
SA-KSWS4/25-1HS28-60	0.664	4	25	13.0	600145
SA-KSWS4/40-1HS28-60	0.768	4	40	15.0	600146
SA-KSWS4/60-1HS28-40	0.942	4	60 <sup>(1)</sup>	17.0	600416
SA-KSWS5/25-1HS28-60	0.724	5	25	13.5	600148
SA-KSWS5/40-1HS28-60	0.861	5	40	16.0	600149
SA-KSWS5/60-1HS28-40	1.035	5	60 <sup>(1)</sup>	19.0	600417
SA-KSWS4/25-1SS28-60	0.584	4	25	11.0	600147
SA-KSWS5/25-1SS28-60	0.624	5	25	12.0	600150

(1) At 40% DC



# DOUBLE COLLECTOR & TOW ARMS

## DOUBLE COLLECTOR DKSW (MAX. SPEED 150 M/MIN.)

Also for conductor systems with sealing strip up to 100 m/min.

The double collectors are supplied as an assembly kit consisting of 2 collectors (KSW) and a connecting bar with mounting material. For the collector KSWs there are no double collectors available 2 single collectors must be used instead.

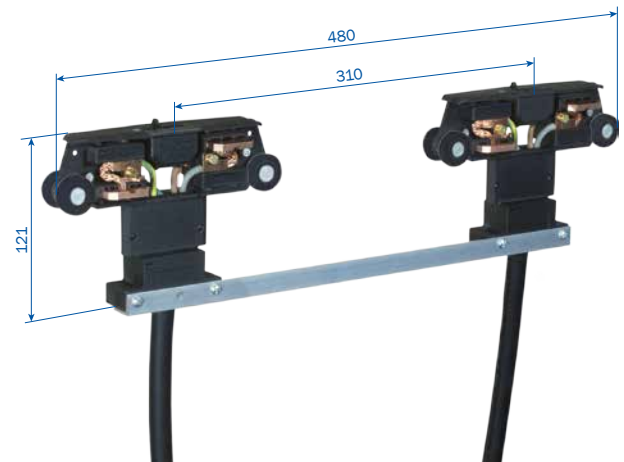

## CONNECTING CABLE

for 50 A with (2x) 2.5 mm<sup>2</sup> / core

for 80 A with (2x) 4.0 mm<sup>2</sup> / core

for 120 A with (2x) 6.0 mm<sup>2</sup> / core

1 m long, longer cables on request.

Order example for 2 m long cables

Order-No. 600119-2 for collector SA-DKSW5/80-2HS28-60

For curves use single collectors only.

Type	Weight kg	Number of poles	Power rating at 60 % DC in A	Approx. diameter of connecting-cables in mm	Order No.
SA-DKSW-4/50-1HS28-60	1.215	4	50	12.5	600115
SA-DKSW4/80-1HS28-60	1.423	4	80	14.5	600116
SA-DKSW4/120-1HS28-40	1.705	4	120 <sup>(1)</sup>	17.0	600414
SA-DKSW5/50-1HS28-60	1.379	5	50	13.5	600118
SA-DKSW5/80-1HS28-60	1.653	5	80	16.0	600119
SA-DKSW5/120-1HS28-40	2.001	5	120 <sup>(1)</sup>	19.0	600415
SA-DKSW4/50-1SS28-60	1.055	4	50	11.0	600117
SA-DKSW5/50-1SS28-60	1.179	5	50	12.0	600120



A-A  
Version with square hollow profile (without adapter plate)



A-A  
Version with tube<sup>(2)</sup>

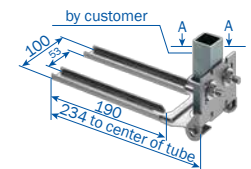

## TOW ARM

Installation options of 30 mm square-, hollow profile or tube with 30–34 mm

Type	Weight kg	Order No.
MN-MGUN	0.436	600887
MN-MGU/K <sup>(3)</sup>	0.550	600336

## TOW ARM

Installation option for plane surface

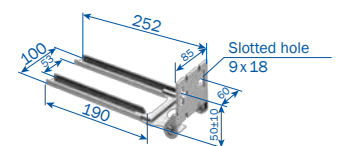

Type	Weight kg	Order No.
MN-MGFN	0.328	600888
MN-MGF/K <sup>(3)</sup>	0.442	600337

(1) At 40% DC

(2) For assembly use enclosed adapter plate

(3) Stainless steel

# FLEXIBLE TOW ARM

## FLEXIBLE TOW ARM

Flexible support type for single collector for installations with transfer funnels type KET (see page 17). Measurements for installation see below.

If you are going to use the flexible towing arm in system with curves please contact us.

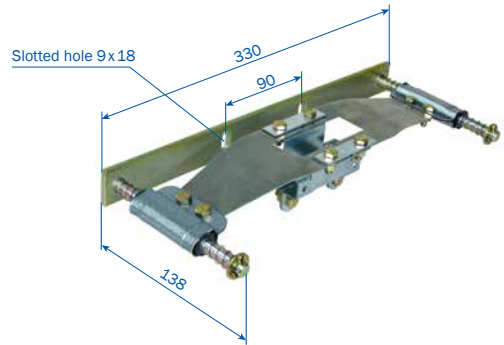

Type	Weight kg	Order No.
MN-KFMHN	1.067	600558

## ARRANGEMENT OF A FLEXIBLE TOW ARM

KFMHN with collector type KSW

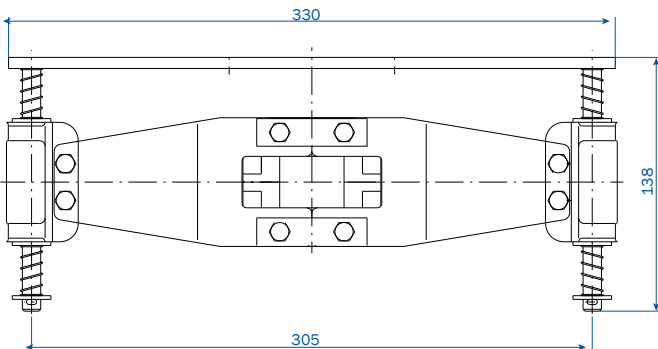
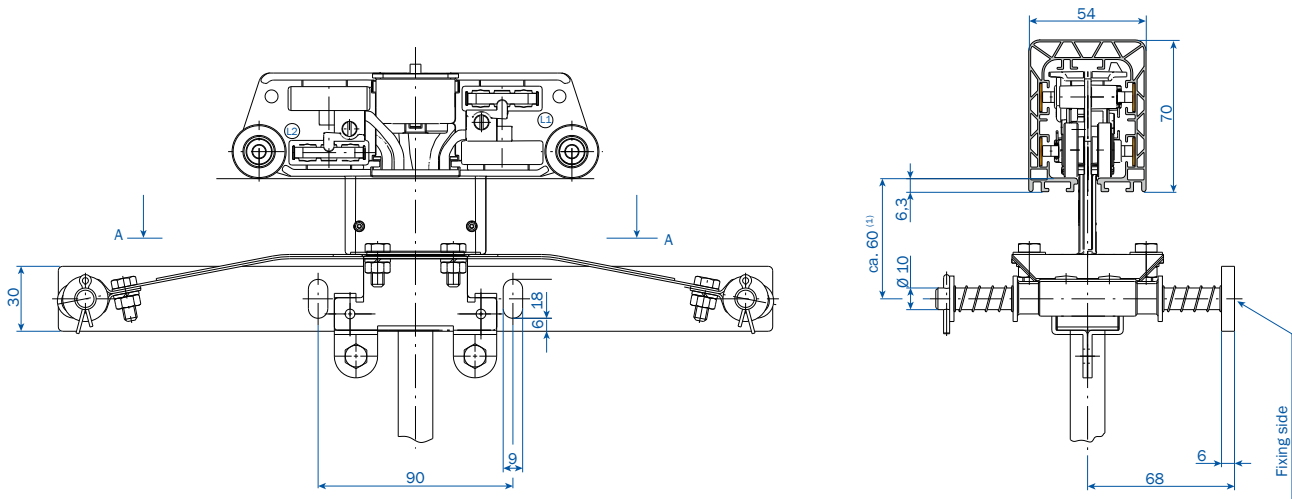

max. horizontal offset 10 mm  
max. vertical offset 10 mm

(1) To be fixed during installation.

## EXAMPLES FOR ORDERING

### INSTALLATION LENGTH OF 64 M KBH... (CONFIGURATION SEE PAGE 6 AND 7)

Quantity	Article	KBHF4/80-...HSC with end feed		KBHF5/100-...HSC with line feed		KBHS5/160-...HSC with line feed incl. 1 m conductor section	
		Type	Order No.	Type	Order No.	Type	Order No.
16	conductor section, 4 m long	KBHF4/80-4000HSC	600984	KBHF5/100-4000HSC	600124	-	-
15	conductor section, 4 m long	-	-	-	-	KBHS5/160-4000HSC	600184
1	conductor section, 3 m long	-	-	-	-	KBHS5/160-3000HSC	600183
1	End feed	ES-KKE4/63-80HS	600010	-	-	-	-
1	Line feed	-	-	ES-KSE5/100HS-L	600039	-	-
1	Line feed, 1 m long	-	-	-	-	ES-KELS5/ 160HSC-1000-2	600079
1	End cap	EK-KE	600008	-	-	-	-
2	End cap	-	-	EK-KE	600008	EK-KE	600008
15	Joint cap	VM-KVM	600005	-	-	-	-
14	Joint cap	-	-	VM-KVM	600005	-	-
16	Joint cap	-	-	-	-	VM-KVM	600005
1	Fixpoint hanger	AH-KFA	600007	AH-KFA	600007	AH-KFA	600007
32	Sliding hanger	AH-KGA	600000	AH-KGA	600000	AH-KGA	600000
1	Current collector	SA-KSW4/40- 1HS28-60	600096	SA-KSW5/ 40-1HS28-60	600099	SA-KSW5/ 40-1HS28-60	600099
1	Tow arm	MN-MGU	600334	MN-MGU	600334	MN-MGU	600334

## EXAMPLES FOR ORDERING

### INSTALLATIONS WITH CURVES AS PER CUSTOMER DRAWING

41.075 m conductor system.

Quantity	Article	KBHF4/80-...HSC		KBHS5/80-...HSC	
		Type	Order No.	Type	Order No.
7	Conductor system, 4 m long	KBHF4/80-4000HSC	600984	KBHS5/80-4000HSC	601074
1	Conductor system, 4 m long for 1x3500 mm short length	KBHF4/80-4000HSC	600984	KBHS5/80-4000HSC	601074
1	Conductor system, 3 m long for 1x2610 mm short length	KBHF4/80-3000HSC	600983	KBHS5/80-2000HSC	601073
1	Conductor system, 2 m long for horizontal curve 45°, R = 2100 mm, L = 1648 mm, SA	KBHF4/80-2000HSC	600982	KBHS4/125-2000HSC	601072
2	Conductor system, 3 m long for horizontal curve 2x45°, R = 2700 mm, L = 2121 mm, SI	KBHF4/80-3000HSC	600983	KBHS5/80-3000HSC	601073
1	End feed	ES-KKE4/63-80HS	600010	ES-KKE5/63-80HS	600107
1	Expansion section	DT-KD4/63-125HSC-1000	600135	DT-KD5/63-125HSC-1000	600138
11	Joint cap	VM-KVM	600005	VM-KVM	600005
4	Fixpoint hanger	AH-KFA	600007	AH-KFA	600007
24	Sliding hanger	AH-KGA	600000	AH-KGA	600000
1	End cap	EK-KE	600008	EK-KE	600008
1	Current collector	SA-KSW4/40-1HS28-60	600096	SA-KSW5/40-1HS28-60	600099
1	Tow arm	MN-MGF	600335	MN-MGF	600335

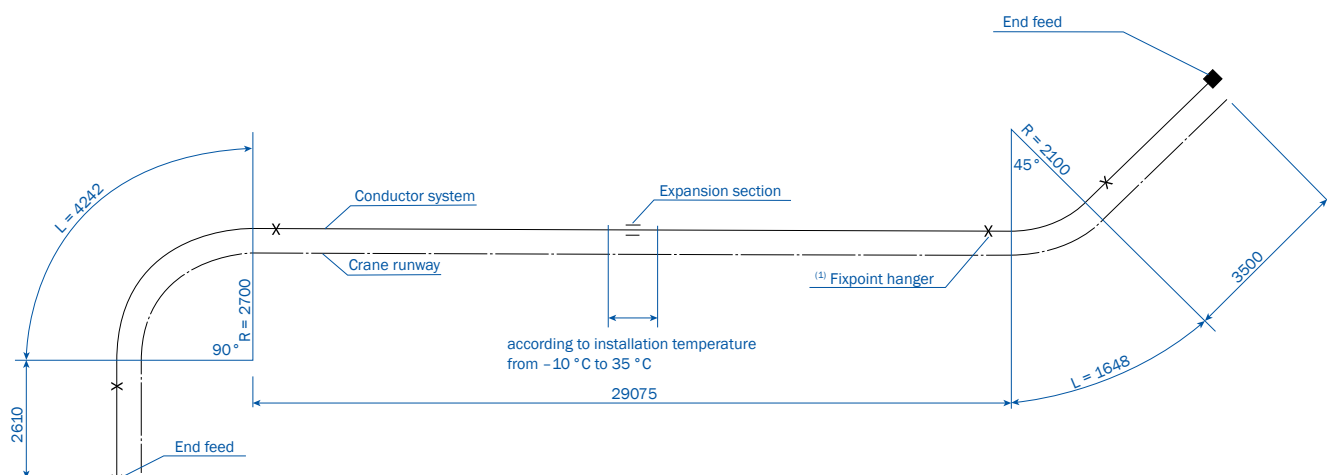

(1) Rest of conductor system to be installed with sliding hangers

# SPARE PART LIST

## SPARE PART LIST FOR CONDUCTOR SYSTEM

Type		KBHF	KBHS
		Order No.	Order No.
VM-KVM	Joint cap (pair)	600005	600005
VM-STV13/63-100A-KBHF/MKHF <sup>(1)</sup>	Spring load connector 63–100 A	600483	-
VM-SCHV13/63-200A-KBHS/MKHS/MKLS <sup>(1)</sup>	Bolted joints 63–160 A	-	262018
VM-SCHV13/200A-KBHS	Bolted joints 200 A	-	600712
DL-D-KBH-MKH-MKL-TDV	Neoprene sealing strip, in pairs (max. length 40 m each)	600551	600551
DL-V-KSLT-KBH-MKL/H-LSV/G	Coupling for sealing strip, in pairs (for lengths <40 m each)	258300	258300
DL-F-KBH	Fixing clamp for sealing strip (1 per end)	600354	600354
DL-EZRD-KBH	Mounting glider for sealing strip (>10 m system length)	600109	600109
AK-KKE-MKE13/63-80-SO <sup>(1)</sup>	Feed terminal for end feed (63/80 A)	600006	600006
AK-KSE-KEF-KES13/63-100 A-S-70.2	Feed terminal for line feed (lateral)	600017	600017
AK-KSE-KEF-KES13/63-100 A-O-67.2	Feed terminal for line feed (on top, 5th conductor)	600016	600016

## SPARE PART LIST FOR CURRENT COLLECTOR

Type		KSW / DKSW	KSW S
		Order No.	Order No.
SK-KSW-MSWA-PH/SU-28	Carbon brush phase (lateral)	600088	600088
SK-KSW-PH/O-28	Carbon brush 5th conductor (top)	600089	600089
SK-KSW-MSWA-PE/S-28	Carbon brush ground (lateral PE)	600090	600090
SA-KF-KSW-MSWA-SP	Carbon pressure spring (standard), suitable for all carbon brushes	600338	600338
TR-DKSW-SB310	Connecting bar for double collector DKSW	600105	-
SA-ZB-AS-KSW-P-250	Assembly kit KSW S	-	600106
SA-ZB-DG-KSW-S	Sealing strip slide plate for collectors KSW	600640	600640

## CLEANING ACCESSORIES ON REQUEST

(1) Also suitable for former 40A-version

## APOS POSITIONING SYSTEM

were developed for automated handling systems in material flow technology.

The control system can constantly query the absolute position of the mobile consumer.

The APOS Positioning system can be used in connection with the VAHLE Powercom® data transmission system.

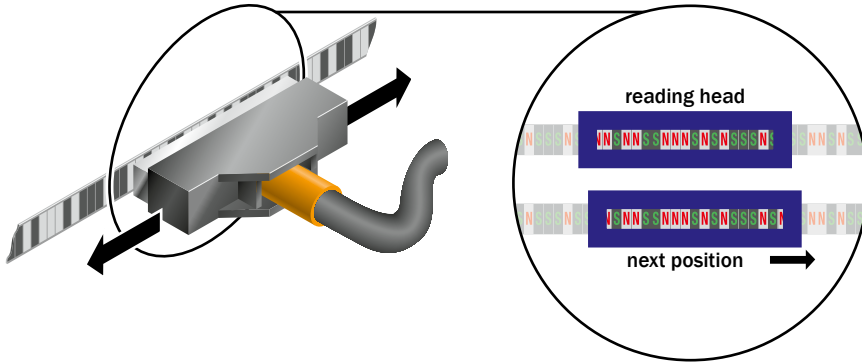

### FEATURES

- absolute position determination up to and 262 m
- Systems for exceeded lengths on request
- Space-saving solutions for integration into the powerail system or for installation in parallel to the runway
- retrofittable
- absolute position immediately available when switching on or after a power failure
- reliable position detection even in humid or dusty environments
- trouble-free functionality even in poor lighting conditions
- travel speed up to 250 m/min
- no wear (contactless)

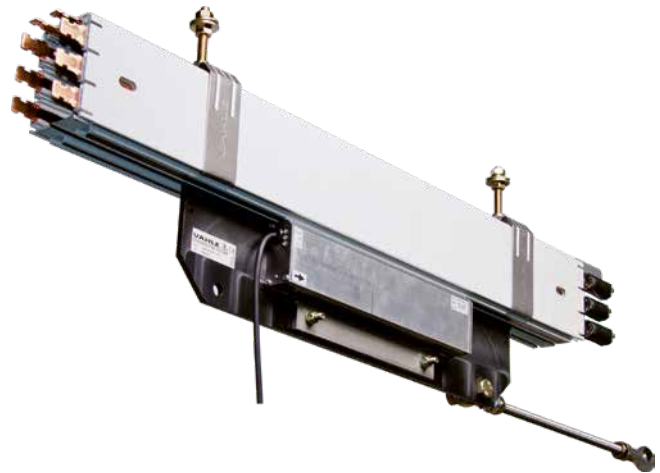

For more information see our catalog VAHLE APOS® (7a)

## VAHLE POWERCOM®

VAHLE Powercom®-Data transmission systems in conjunction with VAHLE conductor bars or sliprings were developed for automated handling systems in material flow technology. They enable the uninterrupted and cost effective data transfer between the central control system and the accompanying automation devices on the conveying vehicles. The VAHLE Powercom® data transmission system can be used in connection with the VAHLE Powercom® data Transmission system.

**19.2  
kbps**



### VAHLE POWERCOM® 485

- RS 485 Interface (transparent protocol)
- to be used in various BUS-Systems.
- Transfer rate 19.2 kbps

For more information see our catalog VAHLE Powercom® (6a)

### EXAMPLE OF USE

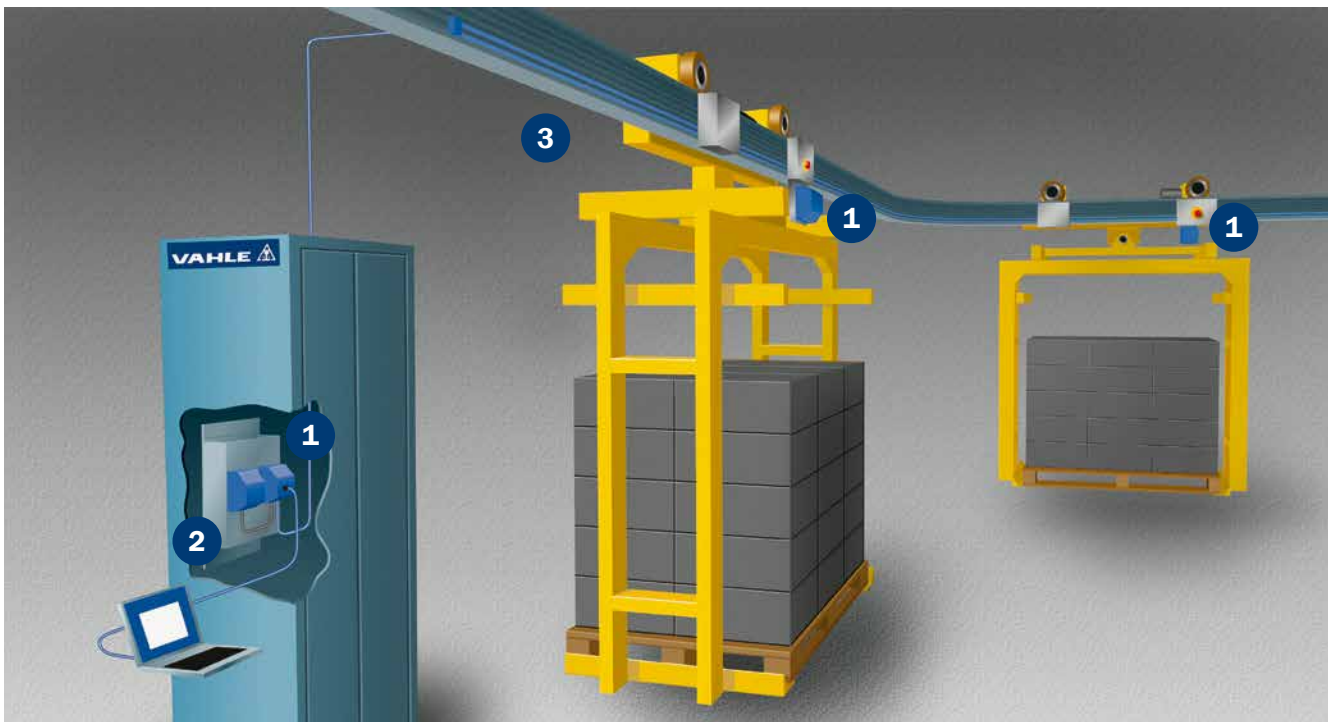

- 1 VAHLE Powercom®
- 2 VAHLE Powercom® Double filter
- 3 VAHLE Powercom® Terminal resistance

# QUESTIONNAIRE

Company: \_\_\_\_\_ Date: \_\_\_\_\_

Fon: \_\_\_\_\_ Fax: \_\_\_\_\_

E-mail: \_\_\_\_\_ Internet: \_\_\_\_\_

1. Number of conductor system installations: \_\_\_\_\_
2. Type of equipment to be powered: \_\_\_\_\_
3. Operating voltage: \_\_\_\_\_ Volt Frequency: \_\_\_\_\_ Hz  
 Three-phase voltage  AC voltage  DC voltage
4. Track length: \_\_\_\_\_
5. Number of conductors: \_\_\_\_\_ neutral: \_\_\_\_\_ control: \_\_\_\_\_ ground: \_\_\_\_\_
6. Mounted position of conductor system:  
 Conductor system pendant, collector cable facing to the bottom  Conductor system pendant, lateral payout of conductor cable<sup>(1)</sup>  
 Support distance \_\_\_\_\_ m (max. 2 m)  Other: \_\_\_\_\_
7. Number of consumers per system: \_\_\_\_\_
8.  Indoor system  Outdoor system
9. Other operating conditions (humidity, dust, chemical influence, etc.) \_\_\_\_\_
10. Ambient temperature: \_\_\_\_\_ °C min. \_\_\_\_\_ °C max.
11. Hall expansion joints \_\_\_\_\_ pieces \_\_\_\_\_ expansion max.
12. Position and number of feeding points<sup>(1)</sup>: \_\_\_\_\_
13. Position and number of isolating sections (e. g. for maintenance)<sup>(1)</sup>: \_\_\_\_\_
14. How will the conductor be arranged?<sup>(1)</sup>: \_\_\_\_\_
15. Brackets required:  Yes  No c/c distance beam/conductor system: \_\_\_\_\_
16. Travel speed: \_\_\_\_\_ m/min. in curves: \_\_\_\_\_ m/min. at transfers: \_\_\_\_\_ m/min.
17. Max. voltage drop from the conductor system feed point to the consumer considering starting current. \_\_\_\_\_
18. Power consumption of the individual consumer loads: \_\_\_\_\_

Motor data	Crane 1						Crane 2							
	Power kW	Nominal current			Starting current		Type of motors <sup>(2)</sup>	Power kW	Nominal current			Starting current		Type of motors <sup>(2)</sup>
		A	cos φ <sub>N</sub>	% duty	A	cos φ <sub>A</sub>			A	cos φ <sub>N</sub>	% duty	A	cos φ <sub>A</sub>	
Hoist motors														
Auxiliary hoist														
Long travel														
Cross travel														

Mark with \* those motors which can run simultaneously.

Mark with Δ those motors which can start up simultaneously.

Further remarks: \_\_\_\_\_

Signature: \_\_\_\_\_

(1) For curved tracks, powerail with isolating sections etc., we require sketches to enable us to prepare a quotation

(2) Use: K for squirrel cage motor, S for slipring motor, F for frequency controlled motor

We reserve all rights to make alterations in the interests of further development

Please copy and fill in the questionnaire.



## PICTURES OF PLANTS

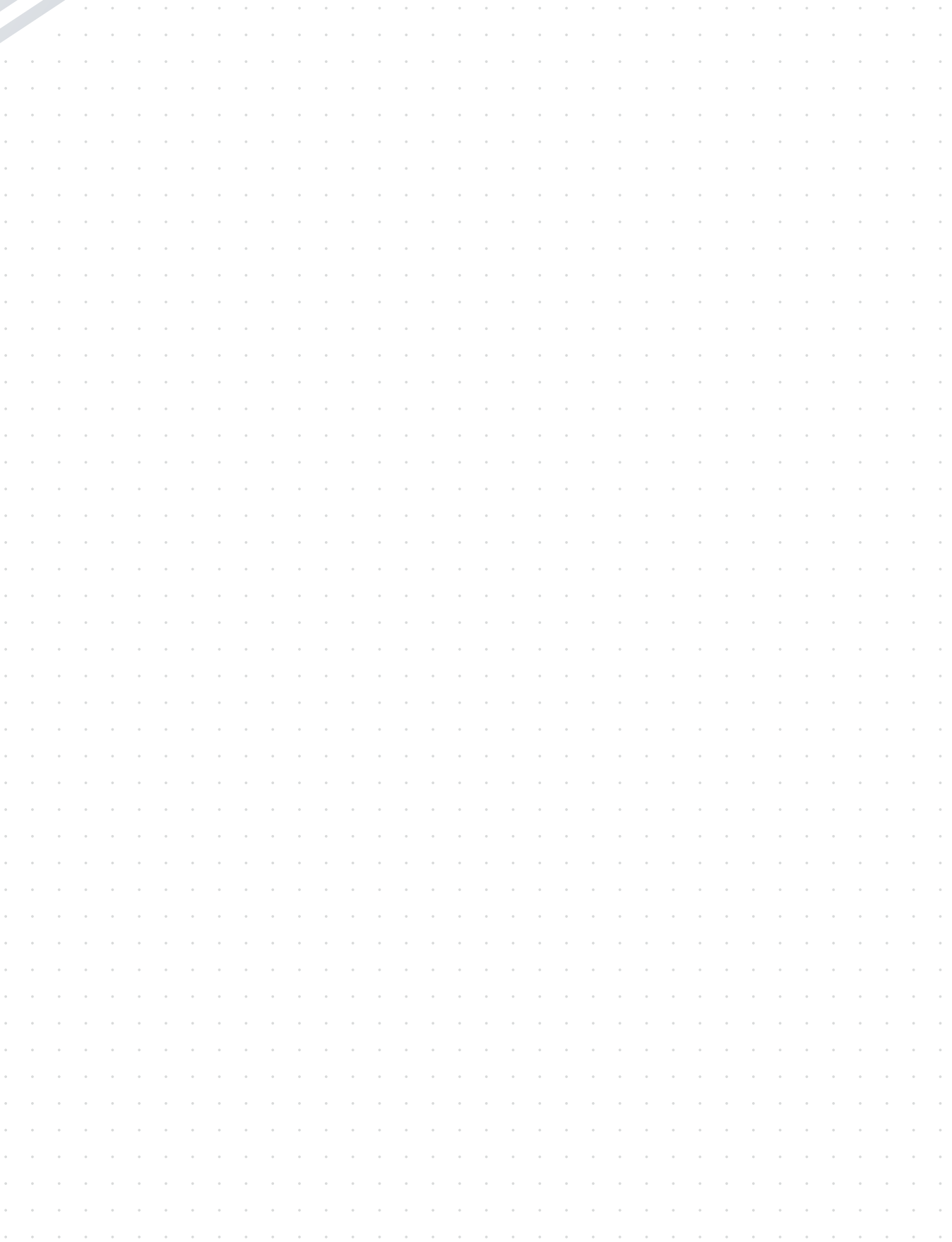

**NOTES**

## NOTES



A large grid of small dots for taking notes, covering most of the page. The dots are arranged in a regular pattern, forming a grid that is approximately 30 columns wide and 40 rows high. The grid is intended for writing notes.

---



**Paul Vahle GmbH & Co. KG**

Westicker Str. 52  
59174 Kamen  
Germany

Tel.: +49 2307 704-0  
Fax: +49 2307 704-444  
info@vahle.de

[www.vahle.com](http://www.vahle.com)